

SWEP DFXD310

The DFX310 is a highly effective, versatile true dual that is a natural choice for chillers and heat pump applications. Its advantage is its ability to offer full performance at both full and partial load. It is optimized for extreme performance with refrigerants. The product is approved for pressures of up to 49 bar (710 psi), so it can be used with the majority of current high-pressure refrigerants, enabling our customers to use the compressor's whole envelope. SWEP's versatile H pressure products enable efficient heat exchange in applications combining small flows and high pressures.

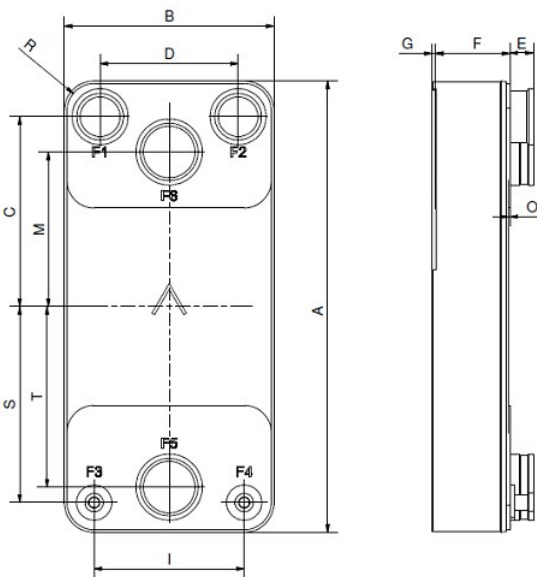

Maximum number of plates (NoP)	350
Max flow	60 m ³ /h (264.17 gpm)
Channel volume	0.177/0.215 dm ³ (0.0063/0.0076 ft ³)
Material	316/316L stainless steel plates, copper brazing
Weight excl. connections	7.75+(0.342*NoP) kg 17.08+(0.754*NoP) lb
Max Particle Size (mm)	0.8



#	MM	IN
A	525	20.67
B	243	9.57
C	221	8.7
D	160	6.3
F	10,00+1,91*(NoP)	0.39+0.08 *(NoP)
G	4	0.16
I	174	6.85
M	180	7.09
O	2	0.08
R	32	1.26
S	228	8.98
T	210	8.27
E_1	27	1.06
E_2	54	2.13

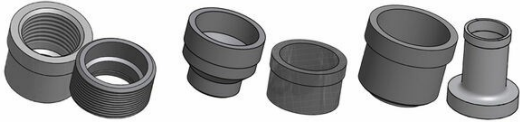

Threaded Connection Victaulic Connection Solder Connection

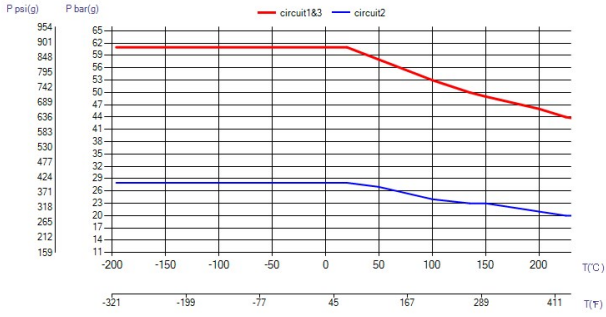

UL Tryck/Temperatur

